

# Robin Z5xx Heatspreader

## Datasheet

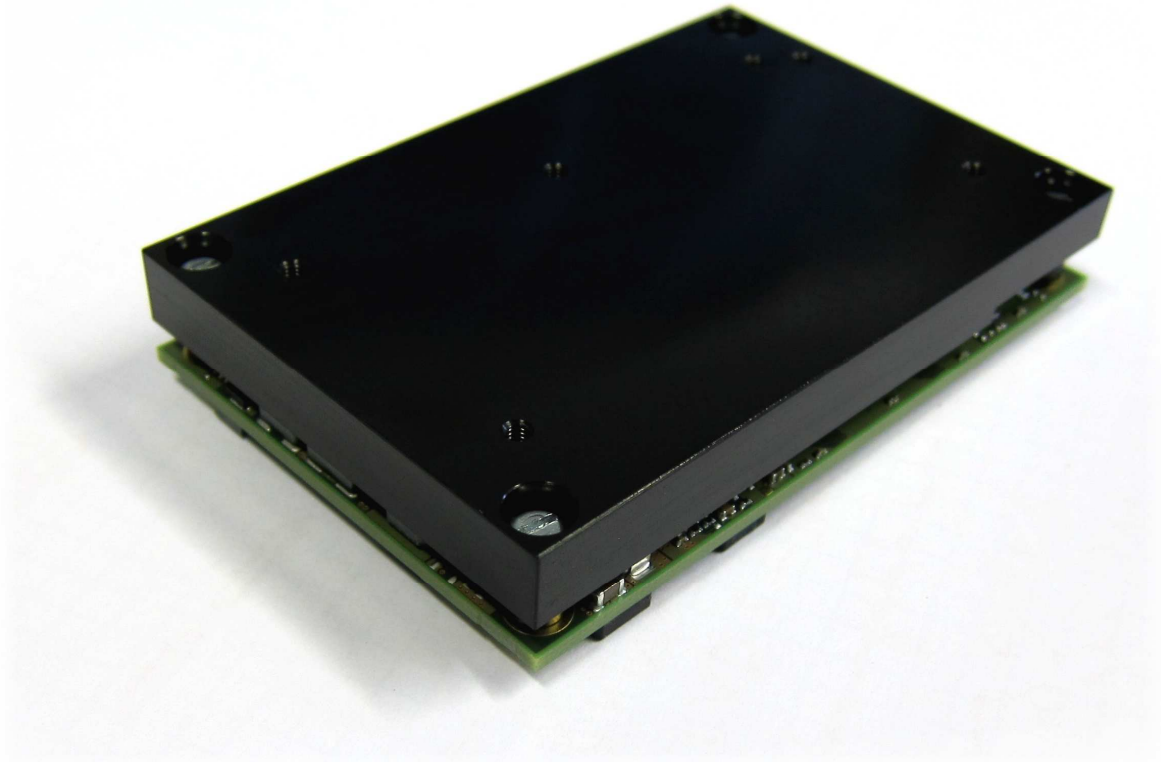

### Revision History

Date	Doc. Rev.	Heatspreader Version	Changes
11-March-09	Rev. 1.0	V1.0	Initial release
25 February 2010	Rev. 1.1	V1.0	Added Compatibility
09-March-2010	Rev. 1.2	V1.0	Added Drawings, new Images
01-Feb-2011	Rev. 1.3	V1.0	New Disclaimer



## Content

1. Introduction	3
2. Technical specifications	3
3. Compatibility	3
4. Heatspreader dimensions	4
5. Assembly	5
5.1. Assembly procedure	5



## 1. Introduction

The heatspreader is an interface between the Robin and its components surfaces and a heat sink. Attaching a heatspreader to the Robin module is not a complete thermal solution. The heatspreader is mounted to the Robin by means of 4 screws of a M2.5 thread. The screws can be mounted from the top or from the bottom. There are additional threaded holes for attaching the heatspreader to a heat sink or a thermal management solution.

## 2. Technical specifications

The following table shows the technical specifications of the heatspreader.

<b>Material</b>	aluminum alloy 6061
<b>Coating</b>	black anodized
<b>Thermal conductivity</b>	180 W/(mK)
<b>Weight</b>	100 gr.
<b>TIM* thermal conductivity</b>	5.5 W/(mK)

TIM = thermal interface material

## 3. Compatibility

Version	Content	Comments
V1.0 A (23021000)	Heatspreader 11.4mm height TIM bubblefoil packaging	Robin Z5xx V1.0: Full compatible Robin Z5xx V2.0: Full compatible, but overall nominal height differ by 0.4mm (tolerance of specification is +/- 0.65mm) *1 Daisy V1.0 and V1.1: compatible, but screws needed Daisy V1.0 and V1.1: compatible, but screws needed Lily V1.0 and V1.1: compatible, but screws needed Lily V2.0 and V2.1: compatible, but screws needed
V1.0 B (23021001)	Heatspreader 11.4mm height TIM M2.5x12mm screws nuts Blister packaging	Robin Z5xx V1.0: Full compatible Robin Z5xx V2.0: Full compatible, but overall nominal height differ by 0.4mm (tolerance of specification is +/- 0.65mm) *1 Daisy V1.0 and V1.1: Full compatible Lily V1.0 and V1.1: Full compatible Lily V2.0: compatible, but longer screws needed *2 Lily V2.1: Full compatible

\*1: COM Express COM.0 specifications required the module together with the heatspreader to have a total height of 13.00mm +/- 0.65mm.

Robin Z5xx V1.0 PCB thickness: 1.6mm -> overall nominal thickness with heatspreader: 13.00mm

Robin Z5xx V2.0 PCB thickness: 2.0mm -> overall nominal thickness with heatspreader: 13.40mm

\*2: Standoffs on Lily V2.0 are M3 threaded, longer screws are needed to mount the Heatspreader on Lily V2.0 carrier board.



## 4. Heatspreader dimensions

The following drawings illustrate the mechanical dimensions of the heatspreader. All measurements are in millimeter.

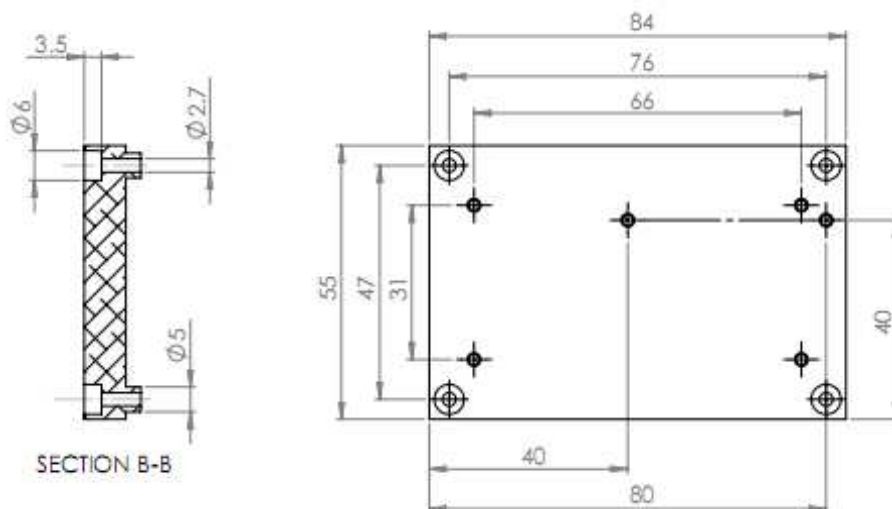
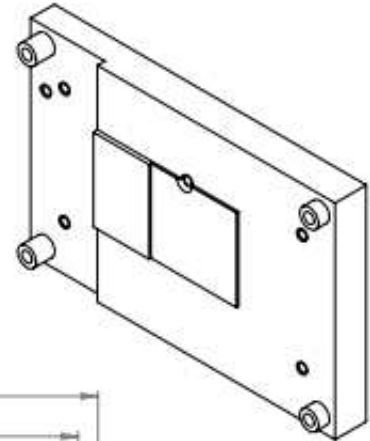
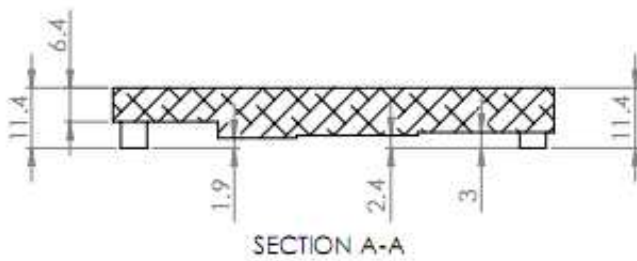
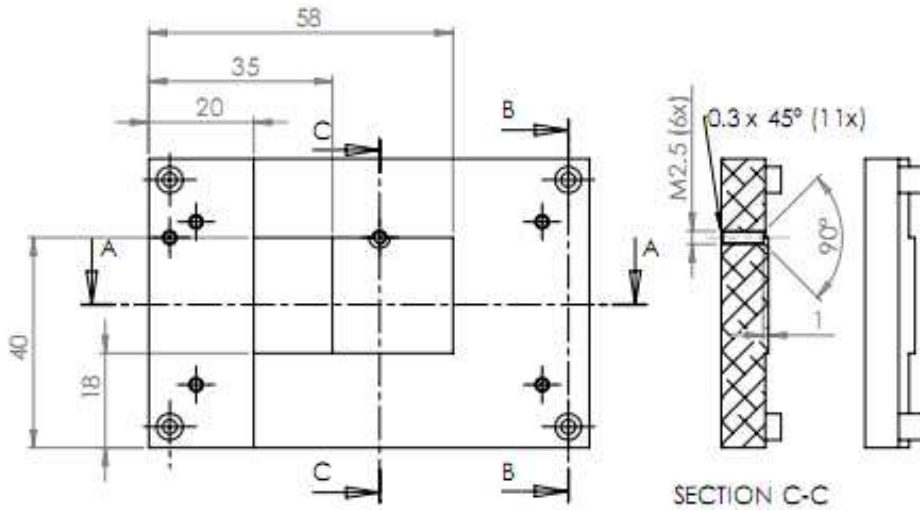



## 5. Assembly

Assembly must be done very carefully since putting the heatspreader in a wrong way will damage the Woodpecker module or may prevent the system to work properly. The screws to used depend on the solution, one possible solution is illustrated below.

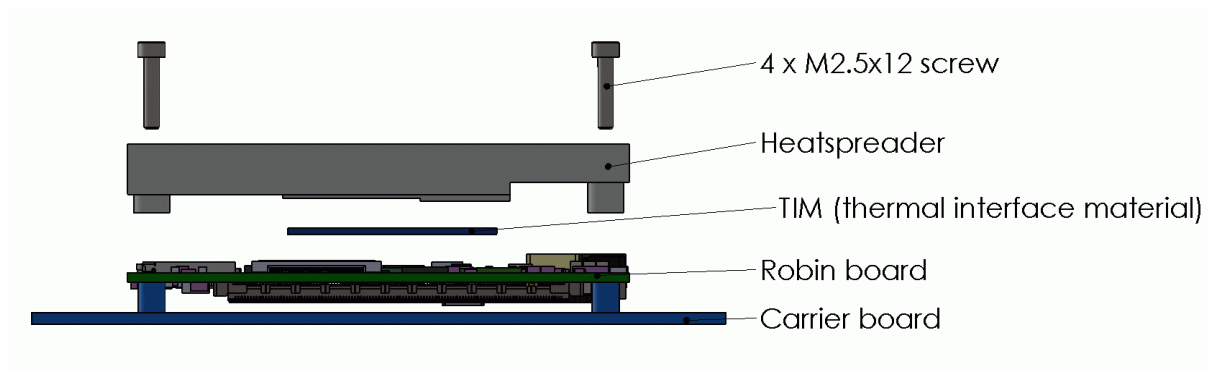

### 5.1. Assembly procedure

The following procedure shows how to attach the thermal interface material (TIM) and the heatspreader on the example of assembling a complete heatsink solution to the Robin module. Please read the procedure very carefully in order not to damage the module.

1. The yellow rectangle shows where the TIM must be placed. That is on the left, the System Controller Hub (=SCH=Poulsbo=US15W) and on the right the Atom (=CPU=Silverthron) processor.

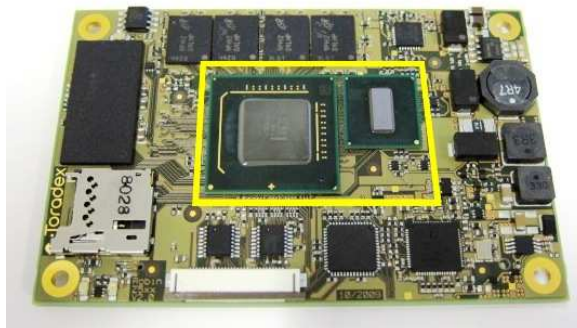

2. Remove the plastic foils on the TIM (on both sides) and attach the TIM as shown over the SCH and CPU.





3. Make sure the TIM covers completely the Silicone of the SCH and CPU (yellow) and is not placed on the capacitor on the right side (green).

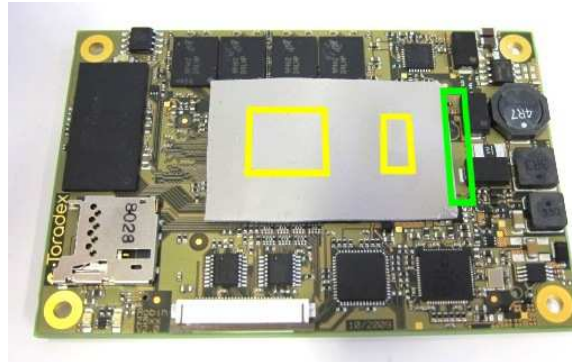

4. On attaching the heatsink, make sure the yellow marked corner is on the right side. (Very important for Robin since the position of the screws don't assure that it is mounted correctly).

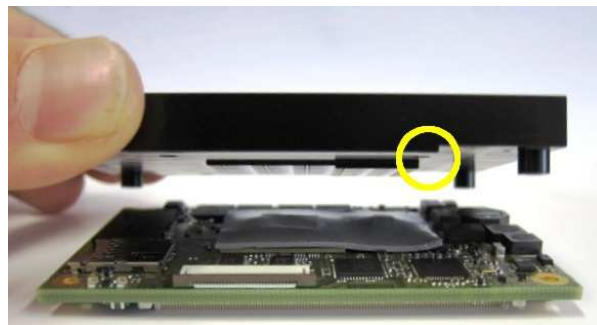

5. Mount the heatsink in a way that the position of the holes is right from the beginning (moving it may not be possible since the TIM sticks the aluminium and print together).



6. Use M2.5 screws to fix the heatsink together with module.



7. Done.



**Disclaimer:**

Copyright © Toradex AG. All rights reserved. All data is for information purposes only and not guaranteed for legal purposes. Information has been carefully checked and is believed to be accurate; however, no responsibility is assumed for inaccuracies. Brand and product names are trademarks or registered trademarks of their respective owners. Specifications are subject to change without notice.

**Trademark Acknowledgement:**

Brand and product names are trademarks or registered trademarks of their respective owners.